



# Model 180 RD 180 kW Diesel Generator Set

## Generator Set Rating

Three Phase	60 Hz kW/KVA	50 Hz kW/KVA
Continuous		
Standby 150°C	180/225	162/202
Prime Power 105°C	162/202	146/182
Single Phase	60 Hz kW/KVA	50 Hz kW/KVA
Continuous		
Standby 150°C	127/127	141/141
Prime Power 105°C	107/107	127/127

## Quality Power Producing Equipment

is our business at Elliott MagneTek Power Systems, Inc.. Our power systems offer solutions to requirements for reliable, quality electrical power.

- 100% full load tested.
- Performance supported by prototype testing.
- 12 lead re-connectable AC synchronous generators.
- Solid state automatic voltage regulator.
- 50 or 60 Hz operational.
- Standard Digital Control Panel meeting standards set by NFPA-110.

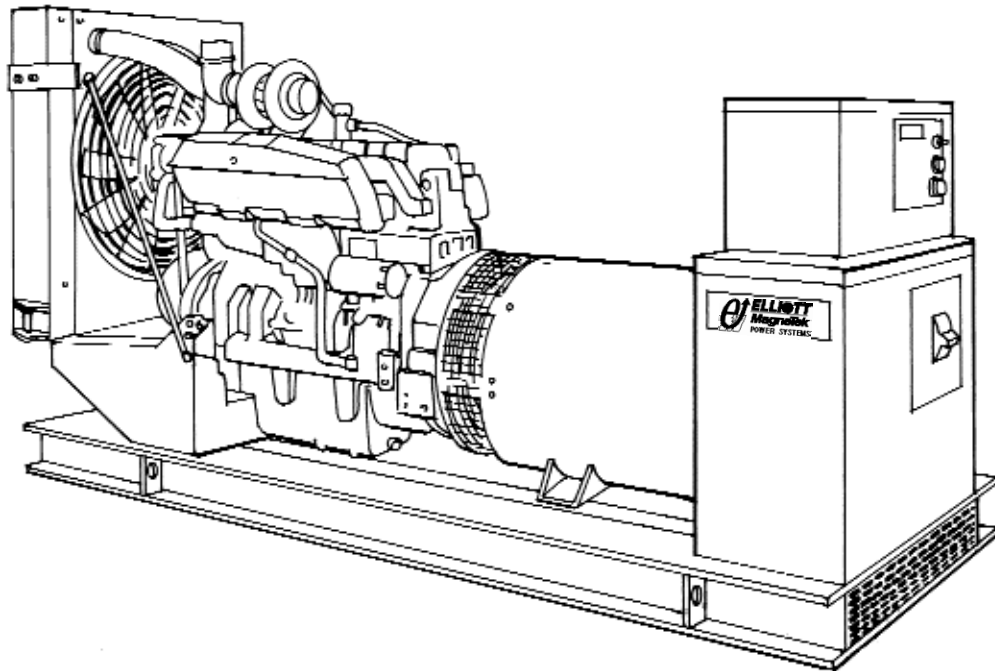

## Product Features

### System Reliability and Longevity

begin with design experience and integrity. EMPS was formed by two companies with over one hundred years experience producing state-of-the-art power generation equipment. This experience is designed into our generator sets.

### Single Source Responsibility:

Product service, support and parts available through EMPS network of distributors.

### Accessories and Flexibility

are designed into EMPS' generator sets at the factory level to meet specific application needs.

### Organizational Commitment

to innovative, leading edge technology and environmentally friendly electrical products and services.

# Generator Set Design Features

## Model 180 RD 180 kW Diesel Generator Set

### Standard Equipment

- \* 4 Cycle engine.
- \* AC synchronous 12 lead re-connectable brushless alternator.
- \* Steel base with vibration isolators between engine, generator and base.
- \* Generator mounted terminal and meter /control box.
- \* Circuit breaker-mounting provisions.
- \* Connection area for main AC terminals and all control wiring
- \* 12 volt DC engine electrical system.
- \* 12 volt starter motor.
- \* Battery charging alternator.
- \* Battery rack and cables.
- \* Flexible fuel lines.
- \* Most metallic parts incorporate our powder paint primer base coat with UV inhibitive enamel top coat.
- \* Single stage dry type air cleaner.
- \* Corrosion resistant hardware.
- \* Oil drain extension plumbed to base rail for convenient connection.
- \* Microprocessor based auto start meter/ control panel.
- \* Digital read out control system rated to operate from -30° C to 75° C with the following standard displays, shown continuously:
  - \*\* Generator AC voltage.
  - \*\* AC amperage:
    - Phase 1-2
    - Phase 2-3
    - Phase 3-1
  - \*\* Frequency
  - \*\* Oil Pressure
  - \*\* Engine Temperature
  - \*\* Battery Voltage
  - \*\* Fuel Level (Diesel Only)
- \* The following can be displayed using the scroll lock function:
  - \*\* Run time
  - \*\* Safety set point for over speed
  - \*\* Over crank
  - \*\* High water temperature
  - \*\* Low oil pressure
- \* Voltage adjust rheostat
- \* Auto/ off /run switch

### Generator Specifications

**Manufacturer:** MagneTek

**Insulation:** The main stator, main rotor, exciter stator and exciter rotor are all insulated with Class H materials and rated Class F per NEMA MG1 -1.65 and 852757 definition. All materials are non-hygroscopic to prevent fungus growth. A polyester and epoxy combination offers maximum environmental protection.

**Main Stator:** 2/3 pitch and one slot skewing minimize voltage harmonics and meets telephone influence factor (TIF) per NEMA MG1-22.43. Twelve lead re-connectable design. Coated with anti-abrasive sealer.

**Main Rotor:** Four pole single piece lamination with full amortisseur windings and coil supports. Winding is precision wet layer wound with epoxy resin and dynamically balanced to two mil in two planes. Production over speed tested at 125% for 15 minutes. All materials are non-hygroscopic to prevent fungus growth.

**Exciter:** Brushless, three phase, six-pole rotor, and production over speed tested at 125% operating speed.

**Rotating Diode:** Sealed full wave with metal oxide surge suppressor

**Bearing:** Double-sealed, permanently lubricated, 50,000 hour B-10 life including magnetic pull.

**Drive Coupling:** Positive alignment, flexible drive discs.

### Automatic Voltage Regulator Specifications

**Operation:** Volts per hertz, three phase sensing with overload and loss of sensing protection.

**Construction:** Solid state, modular: fully sealed and potted design provides component protection from corrosive environments and vibration.

**Voltage Regulation:** +/- 1% voltage regulation no load to full rated load: +/- 1/2% voltage regulation at steady state conditions.

**Radio Interference (RFI):** Integral filter provides suppression of conducted electromagnetic interference to levels meeting most commercial requirements.

### Voltage Selections and Full Load Amperages at Standby Rating

Three Phase

60 Hz Amperage	50 Hz Amperage
120/208 625	110/190 615
120/240 541	120/208 562
277/480 271	230/400 292
347/600 217	240/415 282

\*Single Phase

60 Hz Amperage	50 Hz Amperage
120/240 529	110/220 641

All voltages listed are available and/or re-connectable with the exception of the three phase, 60 Hz, 347/600 volt generator which is application specific. For other voltages, contact your EMPS distributor. All output amperage ratings listed above are at standby rating.

\*Single Phase amperage based on standard generator and unity power factor. For full single phase output use generator model MTG43.

### Application and Performance Data

MagneTek Alternator Model MTG41 is standard with this package. Larger generators may be required to meet certain application specific requirements such as Single Phase, Motor Starting and Non Linear Loads. The Maximum Generator rating available in this package is MTG47.

# Technical Specifications

## Model 180 RD 180 kW Diesel Generator Set

### Engine Specifications

Manufacturer	John Deere	
Model	(180) 6081A	
Type	In line 4 Stroke	
Aspiration	Turbo/ Air to Air Inter cooled	
Cylinders	6	
Displacement	496 In <sup>3</sup> . (8.1 L)	
Bore and Stroke,	4.57 in x 4.92 in. (116 mm x 125 mm)	
Compression Ratio	15.7:1	
Minimum C.C.A. at 5°C	800	
RPM	<b>1800 rpm</b>	<b>1500 rpm</b>
BHP Minimum REQ'D		
at Rated kW	280	252
BMEP	248 psi	268 psi

### Generator Set Deration Factors

Temperature:  
2.5% for every 5° F above 105° F  
2.5% for every 9°C above 41°C

Altitude  
1% for every 1000 feet above  
7500 feet  
1% for every 305 meters above  
2286 meters

### Cooling System

High Ambient 105°F (41°C) System  
Coolant Capacity with Radiator  
45 qt. (42.6 L)

Maximum restriction on discharge side of radiator  
.5 In wc (125 Pa)

	<b>1800 rpm</b>	<b>1500 rpm</b>
Coolant Flow	71 GPM (268.8 LPM)	55 GPM (208.2 LPM)
Heat Rejection to Coolant at Full Load	7110 Btu/min (750 MJ/min)	6140 Btu/min (648 MJ/min)

### Air System

	<b>1800 rpm</b>	<b>1500 rpm</b>
Maximum Air Intake Restriction		30 In wc (7.5 kPa)
Radiator Cooling Air Flow	16000 cfm (452.8 m <sup>3</sup> /min)	14400 cfm (407.5 m <sup>3</sup> /min)
Combustion Air Flow	655 cfm (18.5 m <sup>3</sup> /min)	590 cfm (16.7 m <sup>3</sup> /min)
Generator Cooling Air Flow	2348 cfm (66.4 m <sup>3</sup> /min)	1957 cfm (55.4 m <sup>3</sup> /min)

### Exhaust System

Exhaust Outlet Connection	5.0 in. SAE. Flange	
Maximum Allowable Back Pressure	40.9 In wc (10.2 kPa)	
Exhaust Gas Flow at Standby Rating	1695 cfm (48 m <sup>3</sup> /min)	1526 cfm (43.2 m <sup>3</sup> /min)

Exhaust Temp at Standby Rating	1020°F (549°C)	1095°F (591°C)
--------------------------------	-------------------	-------------------

### Fuel System

Consumption at Standby Rating:

Load	<b>1800 RPM</b>		
	kW	US gal/h	Litre/h
1/4	45	3.6	13.63
1/2	90	6.8	23
3/4	135	10.1	35
Full	180	13.5	46

Load	<b>1500 RPM</b>		
	kW	US gal/h	Litre/h
1/4	40.5	3.0	11.36
1/2	81	5.5	19
3/4	121.5	8.1	28
Full	162	11.4	39

**Governor Type** Mechanical  
**Governor Regulation:**  
+/- 3-5% Steady State

### Generator

Manufacturer	MagneTek	
Model	MTG41	
Motor Starting KVA, 240/480 Volt WYE at 35% Voltage Dip, 100% Voltage Recovery	346 SKVA	
Maximum Motor Starting KVA, 35% Voltage Dip Oversized Generator	780 SKVA	

### Reactances

	480 V	400 V
at 105°C rise	60Hz	50Hz
Synchronous Xd	4.27	4.1
Direct Axis Transient X'd	.449	.431
Direct Axis Subtransient X"d	.274	.263
Zero Sequence Xo	.0052	.0049

### Lubrication System

Engine Oil Capacity with Filters  
8.5 US gal. (36L)  
Oil Filter Type Spin On

### Engine Exhaust Emissions Certification Values

Exhaust Emissions (g/bhp-hr.)	<b>*CARB 180RD</b>	
HC:	1	.5
CO:	8.5	1.2
NOx:	6.9	6.5
PM:	.4	.2

### Smoke Opacity (%)

Acceleration	20	14
Lugging	15	6
Peak	50	21

\* California Air Resources Board Standards.

# Model 180 RD 180 kW Diesel Generator Set

## Options:

### Generator

- \* Upsized
- \* Tropical winding protection
- \* Space heater
- \* Series boost
- \* UL listed mainline circuit breaker

### Control

- \* Remote alarm annunciator
- \* Emergency stop
- \* Multi-point dry contact board.
- \* NFPA 110 Compliance
- \* Low Temperature Display Heater

### Engine

- \* Battery/Battery heater
- \* Battery charger
- \* Engine pre-heater
- \* Fuel/ water separator
- \* Isochronous governor

### Generator Set

- \* EMPS automatic transfer switch
- \* Industrial silencer
- \* Residential silencer
- \* Critical silencer
- \* Weather protective enclosure
- \* Sound attenuation
- \* Sub-base fuel tank

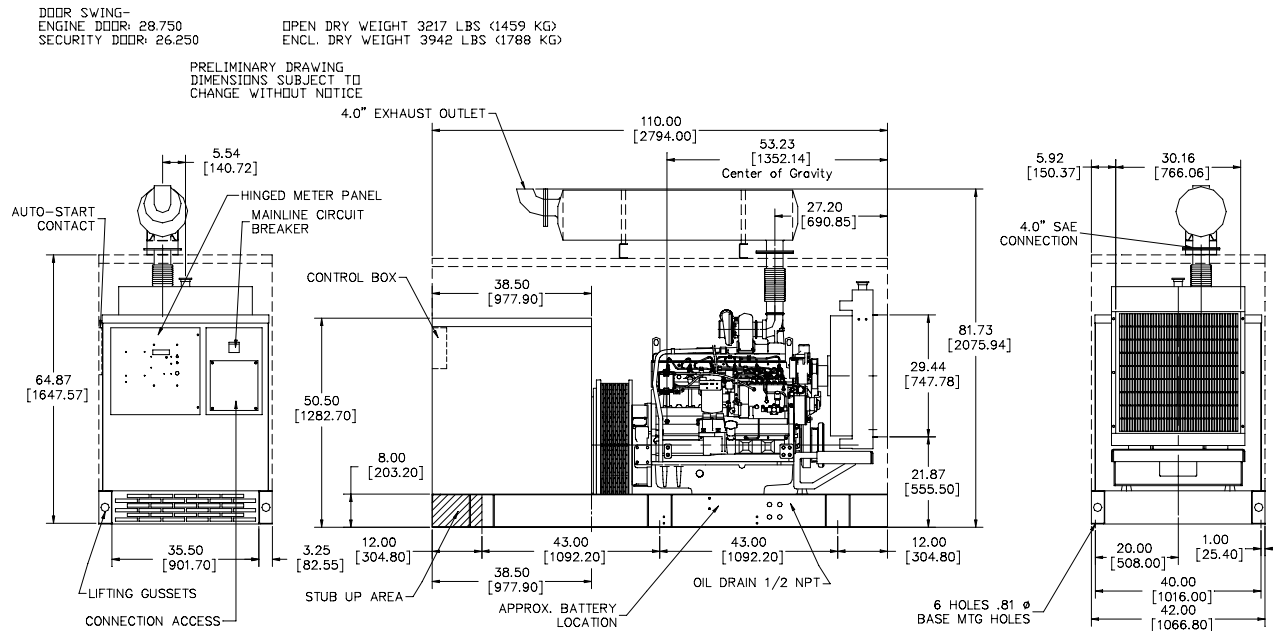

58 Elliott Power Drive  
P.O. Box 403  
Lexington, TN 38351  
Tel: 901-967-9393  
Fax: 901-968-0161

**Distributed by:**



All specifications subject to change without notice. Printed in the USA

Updated 2/00