



Model 2025 RD 2025 kW Diesel Generator Set

Generator Set Rating

Three Phase	60 Hz kW/KVA	50 Hz kW/KVA
Continuous		
Standby 130°C	2025/2531	1825/2281
Prime Power 105°C	1825/2281	1625/2031

Single Phase

Consult Factory

Quality Power Producing Equipment

is our business at Elliott MagneTek Power Systems, Inc.. Our power systems offer solutions to requirements for reliable, quality electrical power.

- 100% full load tested.
- Performance supported by prototype testing.
- 12 lead re-connectable AC synchronous generators.
- Solid state automatic voltage regulator.
- 50 or 60 Hz operational.
- Standard Digital Control Panel meeting standards set by NFPA-110.

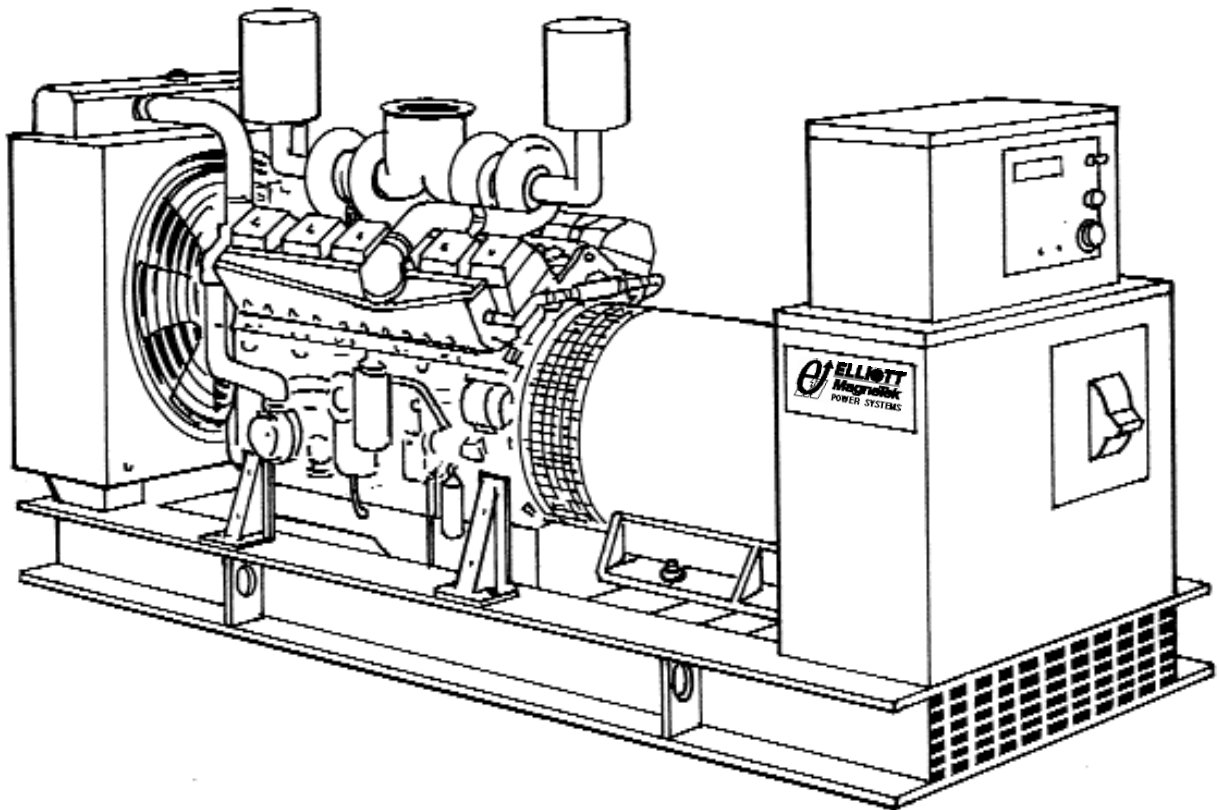

Product Features

System Reliability and Longevity

begin with design experience and integrity. EMPS was formed by two companies with over one hundred years experience producing state-of-the-art power generation equipment. This experience is designed into our generator sets.

Single Source Responsibility:

Product service, support and parts available through EMPS network of distributors.

Accessories and Flexibility

are designed into EMPS' generator sets at the factory level to meet specific application needs.

Organizational Commitment

to innovative, leading edge technology and environmentally friendly electrical products and services.

Generator Set Design Features

Model 2025 RD 2025 kW Diesel Generator Set

Standard Equipment

- * 4 Cycle engine.
- * AC synchronous brushless alternator.
- * Structural "C" channel base.
- * Generator mounted terminal and meter /control box.
- * Circuit breaker-mounting provisions.
- * Connection area for main AC terminals and all control wiring
- * 24 volt DC engine electrical system.
- * 24 volt starter motor.
- * Battery charging alternator.
- * Battery rack and cables.
- * Flexible fuel lines.
- * Most metallic parts incorporate our powder paint primer base coat with UV inhibitive enamel top coat.
- * Single stage dry type air cleaner.
- * Corrosion resistant hardware.
- * Oil drain extension plumbed to base rail for convenient connection.
- * Microprocessor based auto start meter/ control panel.
- * Digital read out control system rated to operate from -30° C to 75° C with the following standard displays, shown continuously:
 - ** Generator AC voltage.
 - ** AC amperage:
 - Phase 1-2
 - Phase 2-3
 - Phase 3-1
 - ** Frequency
 - ** Oil Pressure
 - ** Engine Temperature
 - ** Battery Voltage
 - ** Fuel Level (Diesel Only)
- * The following can be displayed using the scroll lock function:
 - ** Run time
 - ** Safety set point for over speed
 - ** Over crank
 - ** High water temperature
 - ** Low oil pressure
- * Voltage adjust rheostat
- * Auto/ off /run switch

Generator Specifications

Manufacturer: MagneTek

Insulation: The main stator, main rotor, exciter stator and exciter rotor are all insulated with Class H materials and rated Class F per NEMA MG1 -1.65 and 852757 definition. All materials are non-hygroscopic to prevent fungus growth. A polyester and epoxy combination offers maximum environmental protection.

Main Stator: 2/3 pitch and one slot skewing minimize voltage harmonics and meets telephone influence factor (TIF) per NEMA MG1-22.43. Twelve lead re-connectable design. Coated with anti-abrasive sealer.

Main Rotor: Four pole single piece lamination with full amortisseur windings and coil supports. Winding is precision wet layer wound with epoxy resin and dynamically balanced to two mil in two planes. Production over speed tested at 125% for 15 minutes. All materials are non-hygroscopic to prevent fungus growth.

Exciter: Brushless, three phase, six-pole rotor, and production over speed tested at 125% operating speed.

Rotating Diode: Sealed full wave with metal oxide surge suppressor

Bearing: Double-sealed, permanently lubricated, 50,000 hour B-10 life including magnetic pull.

Drive Coupling: Positive alignment, flexible drive discs.

Automatic Voltage Regulator Specifications

Operation: Volts per hertz, three phase sensing with overload and loss of sensing protection.

Construction: Solid state, modular: fully sealed and potted design provides component protection from corrosive environments and vibration.

Voltage Regulation: +/- 1% voltage regulation no load to full rated load: +/- 1/2% voltage regulation at steady state conditions.

Radio Interference (RFI): Integral filter provides suppression of conducted electromagnetic interference to levels meeting most commercial requirements.

Voltage Selections and Full Load Amperages at Standby Rating

Three Phase

60 Hz Amperage	50 Hz Amperage
120/208 7025	110/190 6931
120/240 6089	120/208 6331
277/480 3044	230/400 3292

For other voltages, contact your EMPS distributor. All output amperage ratings listed above are at standby rating.

Application and Performance Data

MagneTek Alternator Model MTG83 is standard with this package. Larger generators may be required to meet certain application specific requirements such as Single Phase, Motor Starting and Non Linear Loads. The Maximum Generator rating available in this package is MTG85.

Technical Specifications

Model 2025 RD 2025 kW Diesel Generator Set

Engine Specifications

Manufacturer	Mitsubishi	
Model	S16R-PTAA2	
Type	4 Cycle Water Cooled	
Aspiration	Turbo/Aftercooler (Jacket water to cooler)	
Cylinders	60° V12	
Displacement	3989 In ³ . (65.37L)	
Bore and Stroke,	6.69 in x 7.09 in. (170 mm x 180 mm)	
Compression Ratio	13.5:1	
Minimum C.C.A. at 5°C	300 Ah	
RPM	1800 rpm	1500 rpm
BHP Minimum REQ'D		
at Rated kW	2798	2522
BMEP	308 psi	333 psi

Generator Set Deration Factors

Temperature:
4% for every 18° F above 104° F
4% for every 10°C above 40°C

Altitude
2.5% for every 383 feet above
4918 feet
2.5% for every 167 meters above
1499 meters

Cooling System

High Ambient 104°F (40°C) System
Coolant Capacity with Radiator
64.2 US gal. (243L)

Maximum restriction on discharge side of radiator .4 In wc (99 Pa)

	1800 rpm	1500 rpm
Coolant Flow		
489 GPM (1850 LPM)	343 GPM (1298 LPM)	
Heat Rejection to Coolant at Full Load	37660 Btu/min (3793 MJ/min)	32817 Btu/min (3462 MJ/min)
Heat Rejection to Room at Rated Full Load	8967 Btu/min (946 MJ/min)	7814 Btu/min (824 MJ/min)

Air System

	1800 rpm	1500 rpm
Maximum Air Intake Restriction		25.0 In wc (6.2 kPa)
Radiator Cooling Air Flow	81213 cfm (2300 m ³ /min)	81213 cfm (2300 m ³ /min)
Combustion Air Flow	6426 cfm (182 m ³ /min)	5615 cfm (159 m ³ /min)
Generator Cooling Air Flow	5256 cfm (148.7 m ³ /min)	4380 cfm (124 m ³ /min)

Exhaust System

Exhaust Outlet Size 8.35 in. dia. (21.2cm)
Maximum Allowable Back Pressure
23.6 In wc (5.9 kPa)

Exhaust Gas Flow at Standby Rating
16808 cfm (476 m³/min) 14654 cfm (415 m³/min)

Exhaust Temp at Standby Rating
950°F (510°C) 1013°F (545°C)

Fuel System

Consumption at Standby Rating:

Load	1800 RPM		
	kW	US gal/h	Litre/h
1/4	506	35.0	132.5
1/2	1012	70.0	265.0
3/4	1518	105.0	397.5
Full	2025	140.0	530.0

Load	1500 RPM		
	kW	US gal/h	Litre/h
1/4	450	29.1	110.2
1/2	900	58.1	219.9
3/4	1350	87.2	330.1
Full	1800	116.2	440.0

Governor Type Electric
Governor Regulation: +/- .25%

Generator

Manufacturer	MagneTek
Model	MTG83
Motor Starting KVA, 240/480 Volt WYE at 35% Voltage Dip, 100% Voltage Recovery	6181 SKVA
Maximum Motor Starting KVA, 35% Voltage Dip Oversized Generator	6704 SKVA

Reactances

	480 V	400 V
at 105°C rise	60Hz	50Hz
Synchronous Xd	3.20	3.07
Direct Axis Transient X'd	.217	.208
Direct Axis Subtransient X'd	.134	.129
Zero Sequence Xo	.0279	.0268

Lubrication System

Engine Oil Capacity with Filters 60.8 US gal. (230L)
Oil Filter Type Spin On

Model 2025 RD 2025 kW Diesel Generator Set

Options:

Generator

- * Upsized
- * Tropical winding protection
- * Space heater
- * Series boost
- * UL listed mainline circuit breaker

Control

- * Remote alarm annunciator
- * Emergency stop
- * Multi-point dry contact board.
- * NFPA 110 Compliance
- * Low Temperature Display Heater

Engine

- * Battery/Battery heater
- * Battery charger
- * Engine pre-heater
- * Fuel/ water separator
- * Isochronous governor

Generator Set

- * EMPS automatic transfer switch
- * Industrial silencer
- * Residential silencer
- * Critical silencer
- * Weather protective enclosure
- * Sound attenuation
- * Sub-base fuel tank

Consult Factory for Current Design

58 Elliott Power Drive
P.O. Box 403
Lexington, TN 38351
Tel: 901-967-9393
Fax: 901-968-0161

Distributed by:



All specifications subject to change without notice. Printed in the USA

Updated 2/00