



Model 70 RD 70 kW Diesel Generator Set

Generator Set Rating

Three Phase	60 Hz kW/KVA	50 Hz kW/KVA
Continuous		
Standby 150°C	70/87	63/78
Prime Power 105°C	63/78	57/71
Single Phase	60 Hz kW/KVA	50 Hz kW/KVA
Continuous		
Standby 150°C	47/47	48/48
Prime Power 105°C	40/40	40/40

Quality Power Producing Equipment

is our business at Elliott MagneTek Power Systems, Inc.. Our power systems offer solutions to requirements for reliable, quality electrical power.

- 100% full load tested.
- Performance supported by prototype testing.
- 12 lead re-connectable AC synchronous generators.
- Solid state automatic voltage regulator.
- 50 or 60 Hz operational.
- Standard Digital Control Panel meeting standards set by NFPA-110.

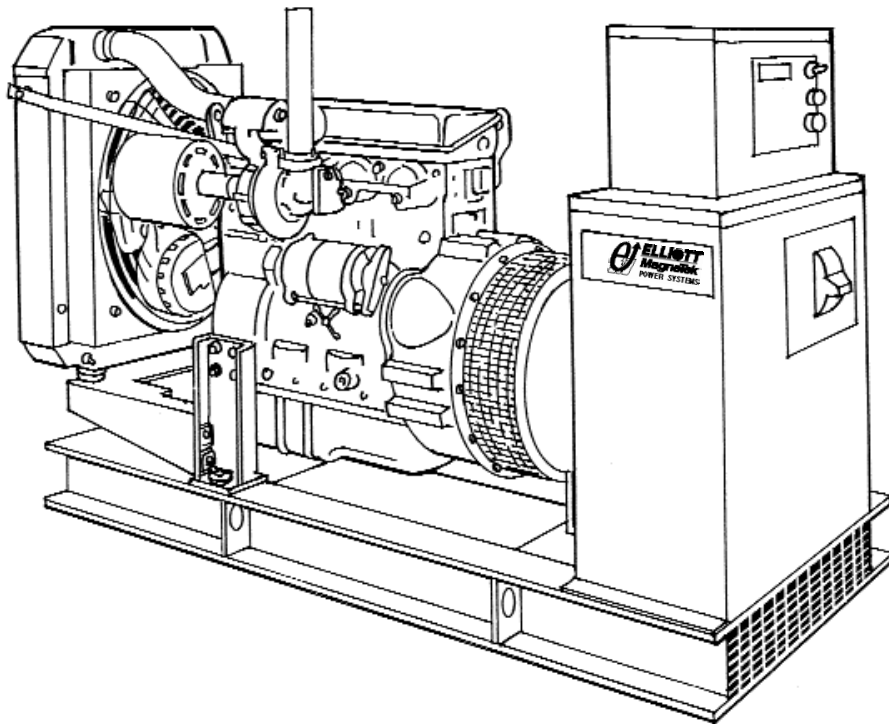

Product Features

System Reliability and Longevity

begin with design experience and integrity. EMPS was formed by two companies with over one hundred years experience producing state-of-the-art power generation equipment. This experience is designed into our generator sets.

Single Source Responsibility:

Product service, support and parts available through EMPS network of distributors.

Accessories and Flexibility

are designed into EMPS' generator sets at the factory level to meet specific application needs.

Organizational Commitment

to innovative, leading edge technology and environmentally friendly electrical products and services.

Generator Set Design Features

Model 70 RD 70 kW Diesel Generator Set

Standard Equipment

- * 4 Cycle engine.
- * AC synchronous 12 lead re-connectable brushless alternator.
- * Steel base with vibration isolators between engine, generator and base.
- * Generator mounted terminal and meter /control box.
- * Circuit breaker-mounting provisions.
- * Connection area for main AC terminals and all control wiring
- * 12 volt DC engine electrical system.
- * 12 volt starter motor.
- * Battery charging alternator.
- * Battery rack and cables.
- * Flexible fuel lines.
- * Most metallic parts incorporate our powder paint primer base coat with UV inhibitive enamel top coat.
- * Single stage dry type air cleaner.
- * Corrosion resistant hardware.
- * Oil drain extension plumbed to base rail for convenient connection.
- * Microprocessor based auto start meter/ control panel.
- * Digital read out control system rated to operate from -30° C to 75° C with the following standard displays, shown continuously:
 - ** Generator AC voltage.
 - ** AC amperage:
 - Phase 1-2
 - Phase 2-3
 - Phase 3-1
 - ** Frequency
 - ** Oil Pressure
 - ** Engine Temperature
 - ** Battery Voltage
 - ** Fuel Level (Diesel Only)
- * The following can be displayed using the scroll lock function:
 - ** Run time
 - ** Safety set point for over speed
 - ** Over crank
 - ** High water temperature
 - ** Low oil pressure
- * Voltage adjust rheostat
- * Auto/ off /run switch

Generator Specifications

Manufacturer: MagneTek

Insulation: The main stator, main rotor, exciter stator and exciter rotor are all insulated with Class H materials and rated Class F per NEMA MG1 -1.65 and 852757 definition. All materials are non-hygroscopic to prevent fungus growth. A polyester and epoxy combination offers maximum environmental protection.

Main Stator: 2/3 pitch and one slot skewing minimize voltage harmonics and meets telephone influence factor (TIF) per NEMA MG1-22.43. Twelve lead re-connectable design. Coated with anti-abrasive sealer.

Main Rotor: Four pole single piece lamination with full amortisseur windings and coil supports. Winding is precision wet layer wound with epoxy resin and dynamically balanced to two mil in two planes. Production over speed tested at 125% for 15 minutes. All materials are non-hygroscopic to prevent fungus growth.

Exciter: Brushless, three phase, six-pole rotor, and production over speed tested at 125% operating speed.

Rotating Diode: Sealed full wave with metal oxide surge suppressor

Bearing: Double-sealed, permanently lubricated, 50,000 hour B-10 life including magnetic pull.

Drive Coupling: Positive alignment, flexible drive discs.

Automatic Voltage Regulator Specifications

Operation: Volts per hertz, three phase sensing with overload and loss of sensing protection.

Construction: Solid state, modular: fully sealed and potted design provides component protection from corrosive environments and vibration.

Voltage Regulation: +/- 1% voltage regulation no load to full rated load: +/- 1/2% voltage regulation at steady state conditions.

Radio Interference (RFI): Integral filter provides suppression of conducted electromagnetic interference to levels meeting most commercial requirements.

Voltage Selections and Full Load Amperages at Standby Rating

Three Phase

60 Hz Amperage	50 Hz Amperage
120/208 243	110/190 239
120/240 210	120/208 219
277/480 105	230/400 114
347/600 84	240/415 110

*Single Phase

60 Hz Amperage	50 Hz Amperage
120/240 195	110/220 218

All voltages listed are available and/or re-connectable with the exception of the three phase, 60 Hz, 347/600 volt generator which is application specific. For other voltages, contact your EMPS distributor. All output amperage ratings listed above are at standby rating.

*Single Phase amperage based on standard generator and unity power factor. For full single phase output use generator model MTG35.

Application and Performance Data

MagneTek Alternator Model MTG29 is standard with this package. Larger generators may be required to meet certain application specific requirements such as Single Phase, Motor Starting and Non Linear Loads. The Maximum Generator rating available in this package is MTG44.

Technical Specifications

Model 70 RD 70 kW Diesel Generator Set

Engine Specifications

Manufacturer	Isuzu	
Model	6BG1TPV	
Type	In line 4 Stroke	
Aspiration	Turbo	
Cylinders	6	
Displacement	396 In ³ . (6.5 L)	
Bore and Stroke,	4.13 in x 4.92 in. (105 mm x 125 mm)	
Compression Ratio	17.5:1	
Minimum C.C.A. at 5°C	780	
RPM	1800 rpm	1500 rpm
BHP Minimum REQ'D		
at Rated kW	104	94
BMEP	173 psi	188 psi

Generator Set Deration Factors

Temperature:
2.5% for every 5° F above 105° F
2.5% for every 9°C above 41°C

Altitude
2% for every 2000 feet above
2000 feet
2% for every 607 meters above
607 meters

Cooling System

High Ambient 105°F (41°C) System
Coolant Capacity with Radiator
24 qt. (22.7 L)

Maximum restriction on discharge side of radiator
.5 In wc (125 Pa)

	1800 rpm	1500 rpm
Coolant Flow		
	57 GPM (215 LPM)	49 GPM (185 LPM)
Heat Rejection to Coolant at Full Load		
	4250 Btu/min (448 MJ/min)	3700 Btu/min (390 MJ/min)

Air System

	1800 rpm	1500 rpm
Maximum Air Intake Restriction		30 In wc (7.5 kPa)
Radiator Cooling Air Flow	5600 cfm (158.5m ³ /min)	5040 cfm (142.6 m ³ /min)
Combustion Air Flow	240 cfm (6.8 m ³ /min)	185 cfm (5.2 m ³ /min)
Generator Cooling Air Flow	1003 cfm (28.4 m ³ /min)	860 cfm (24.3 m ³ /min)

Exhaust System

Exhaust Manifold Outlet Size	3.0 in. dia. (7.6 cm)	
Maximum Allowable Back Pressure	40.9 In wc (10.2 kPa)	
Exhaust Gas Flow at Standby Rating	650 cfm (18.4 m ³ /min)	550 cfm (15.6 m ³ /min)

Exhaust Temp at Standby Rating

1090°F (588°C)	1090°F (588°C)
-------------------	-------------------

Fuel System

Consumption at Standby Rating:

Load	1800 RPM		
	kW	US gal/h	Litre/h
1/4	17	1.2	4.5
1/2	35	2.3	8.7
3/4	52	3.5	13.2
Full	70	4.6	17.4
Load	1500 RPM		
	kW	US gal/h	Litre/h
1/4	13.	.98	3.7
1/2	27	1.9	7.2
3/4	47	2.9	11.0
Full	63	3.9	14.8

Governor Type Mechanical

Governor Regulation:
+/- 3-5% Steady State

Generator

Manufacturer	MagneTek	
Model	MTG29	
Motor Starting KVA, 240/480 Volt WYE at 35% Voltage Dip, 100% Voltage Recovery	214 SKVA	
Maximum Motor Starting KVA, 35% Voltage Dip Oversized Generator	346 SKVA	

Reactances

	480 V	400 V
at 105°C rise	60Hz	50Hz
Synchronous Xd	2.46	2.67
Direct Axis Transient X'd	.161	.175
Direct Axis Subtransient X'd	.114	.124
Zero Sequence Xo	.0025	.0027

Lubrication System

Engine Oil Capacity with Filters
3 US gal. (11 L)
Oil Filter Type Spin On

Engine Exhaust Emissions Certification Values

Exhaust Emissions (g/bhp-hr.)	*CARB	70RD
	HC:	1
CO:	3.7	.5
NOx:	6.9	5.7
PM:	.52	.17

Smoke Opacity (%)

Acceleration	20	11
Lugging	15	3
Peak	50	20

* California Air Resources Board Standards.

Model 70 RD 70 kW Diesel Generator Set

Options:

Generator

- * Upsized
- * Tropical winding protection
- * Space heater
- * Series boost
- * UL listed mainline circuit breaker

Control

- * Remote alarm annunciator
- * Emergency stop
- * Multi-point dry contact board.
- * NFPA 110 Compliance
- * Low Temperature Display Heater

Engine

- * Battery/Battery heater
- * Battery charger
- * Engine pre-heater
- * Fuel/ water separator
- * Isochronous governor

Generator Set

- * EMPS automatic transfer switch
- * Industrial silencer
- * Residential silencer
- * Critical silencer
- * Weather protective enclosure
- * Sound attenuation
- * Sub-base fuel tank

OPEN DRY WEIGHT 2305 LBS (1045 KG)
ENCL. DRY WEIGHT 2855 LBS (1295 KG)

DOOR SWING
SECURITY DOOR: 35.62"
ENGINE DOOR: 35.62"

PRELIMINARY DRAWING
DIMENSIONS SUBJECT TO
CHANGE WITHOUT NOTICE

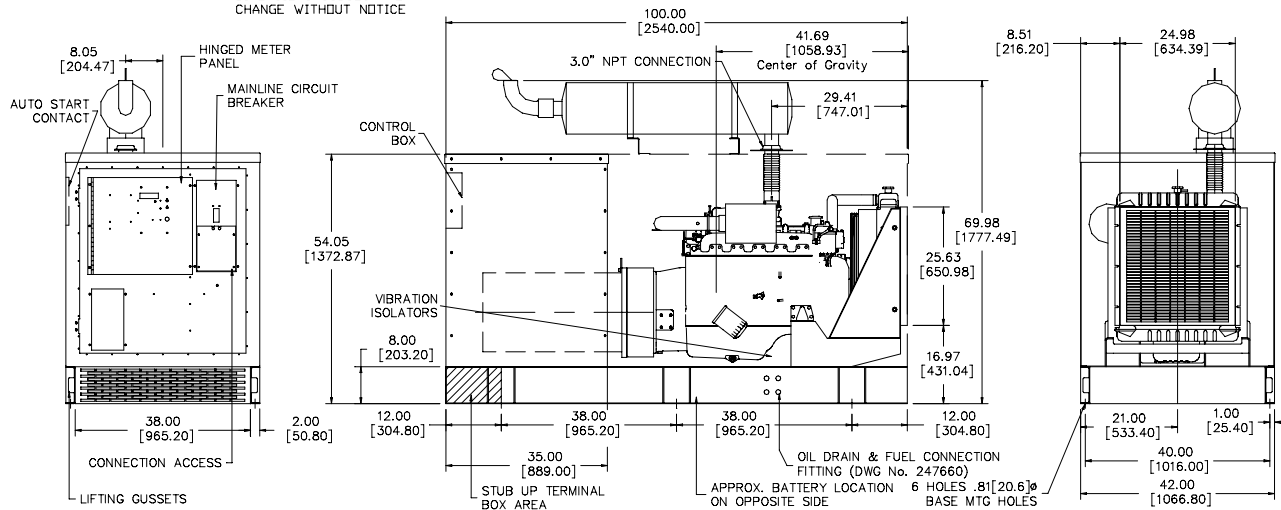

58 Elliott Power Drive
P.O. Box 403
Lexington, TN 38351
Tel: 901-967-9393
Fax: 901-968-0161

Distributed by:



All specifications subject to change without notice. Printed in the USA

Updated 2/00