



Model 30 RNIL 30 kW Natural Gas\ LP Generator Set

Generator Set Rating

Three Phase	60 Hz kW/KVA	50 Hz kW/KVA
Continuous		
Standby 150°C	30/37	27/33
Prime Power 105°C	27/33	24/30
Single Phase	60 Hz kW/KVA	50 Hz kW/KVA
Continuous		
Standby 150°C	17/17	19/19
Prime Power 105°C	14/14	16/16

Quality Power Producing Equipment

is our business at Elliott MagneTek Power Systems, Inc.. Our power systems offer solutions to requirements for reliable, quality electrical power.

- 100% full load tested.
- Performance supported by prototype testing.
- 12 lead re-connectable AC synchronous generators.
- Solid state automatic voltage regulator.
- 50 or 60 Hz operational.
- Standard Digital Control Panel meeting standards set by NFPA-110.

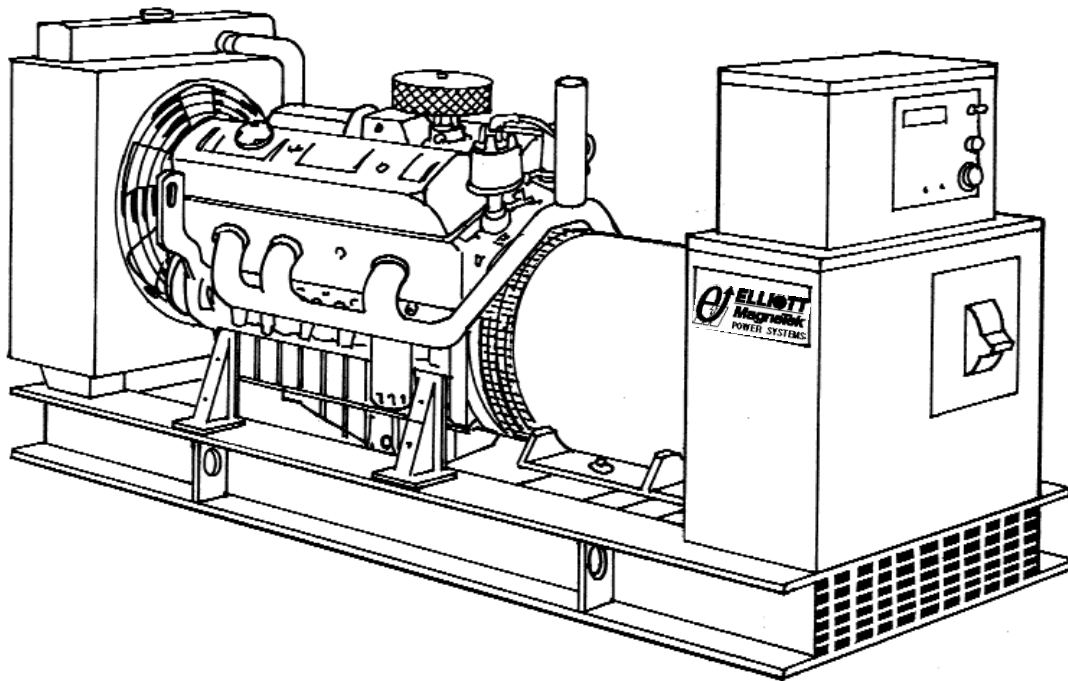

Product Features

System Reliability and Longevity

begin with design experience and integrity. EMPS was formed by two companies with over one hundred years experience producing state-of-the-art power generation equipment. This experience is designed into our generator sets.

Single Source Responsibility:

Product service, support and parts available through EMPS network of distributors.

Accessories and Flexibility

are designed into EMPS' generator sets at the factory level to meet specific application needs.

Organizational Commitment

to innovative, leading edge technology and environmentally friendly electrical products and services.

Generator Set Design Features

Model 30 RN\ L 30 kW NG\ LP Generator Set

Standard Equipment

- * 4 Cycle engine.
- * AC synchronous 12 lead re-connectable brushless alternator.
- * Steel base with vibration isolators between engine, generator and base.
- * Generator mounted terminal and meter /control box.
- * Circuit breaker-mounting provisions.
- * Connection area for main AC terminals and all control wiring
- * 12 volt DC engine electrical system.
- * 12 volt starter motor.
- * Battery charging alternator.
- * Battery rack and cables.
- * Flexible fuel lines.
- * Most metallic parts incorporate our powder paint primer base coat with UV inhibitive enamel top coat.
- * Single stage dry type air cleaner.
- * Corrosion resistant hardware.
- * Oil drain extension plumbed to base rail for convenient connection.
- * Microprocessor based auto start meter/ control panel.
- * Digital read out control system rated to operate from -30° C to 75° C with the following standard displays, shown continuously:
 - ** Generator AC voltage.
 - ** AC amperage:
 - Phase 1-2
 - Phase 2-3
 - Phase 3-1
 - ** Frequency
 - ** Oil Pressure
 - ** Engine Temperature
 - ** Battery Voltage
 - ** Fuel Level (Diesel Only)
- * The following can be displayed using the scroll lock function:
 - ** Run time
 - ** Safety set point for over speed
 - ** Over crank
 - ** High water temperature
 - ** Low oil pressure
- * Voltage adjust rheostat
- * Auto/ off /run switch

Generator Specifications

Manufacturer: MagneTek

Insulation: The main stator, main rotor, exciter stator and exciter rotor are all insulated with Class H materials and rated Class F per NEMA MG1 -1.65 and 852757 definition. All materials are non-hygroscopic to prevent fungus growth. A polyester and epoxy combination offers maximum environmental protection.

Main Stator: 2/3 pitch and one slot skewing minimize voltage harmonics and meets telephone influence factor (TIF) per NEMA MG1-22.43. Twelve lead re-connectable design. Coated with anti-abrasive sealer.

Main Rotor: Four pole single piece lamination with full amortisseur windings and coil supports. Winding is precision wet layer wound with epoxy resin and dynamically balanced to two mil in two planes. Production over speed tested at 125% for 15 minutes. All materials are non-hygroscopic to prevent fungus growth.

Exciter: Brushless, three phase, six-pole rotor, and production over speed tested at 125% operating speed.

Rotating Diode: Sealed full wave with metal oxide surge suppressor

Bearing: Double-sealed, permanently lubricated, 50,000 hour B-10 life including magnetic pull.

Drive Coupling: Positive alignment, flexible drive discs.

Automatic Voltage Regulator Specifications

Operation: Volts per hertz, three phase sensing with overload and loss of sensing protection.

Construction: Solid state, modular: fully sealed and potted design provides component protection from corrosive environments and vibration.

Voltage Regulation: +/- 1% voltage regulation no load to full rated load: +/- 1/2% voltage regulation at steady state conditions.

Radio Interference (RFI): Integral filter provides suppression of conducted electromagnetic interference to levels meeting most commercial requirements.

Voltage Selections and Full Load Amperages at Standby Rating

Three Phase

60 Hz Amperage	50 Hz Amperage
120/208	104 110/190 103
120/240	90 120/208 94
277/480	45 230/400 49
347/600	36 240/415 47

*Single Phase

60 Hz Amperage	50 Hz Amperage
120/240	71 110/220 86

All voltages listed are available and/or re-connectable with the exception of the three phase, 60 Hz, 347/600 volt generator which is application specific. For other voltages, contact your EMPS distributor. All output amperage ratings listed above are at standby rating.

*Single Phase amperage based on standard generator and unity power factor. For full single phase output use generator model MTG24.

Application and Performance Data

MagneTek Alternator Model MTG22 is standard with this package. Larger generators may be required to meet certain application specific requirements such as Single Phase, Motor Starting and Non Linear Loads. The Maximum Generator rating available in this package is MTG27.

Technical Specifications

Model 30 RN\ L 30 kW NG\ LP Generator Set

Engine Specifications

Manufacturer	General Motors	
Model	4.3 L	
Aspiration	Natural	
Cylinders	V-6	
Displacement	262 In ³ . (4.3 L)	
Bore and Stroke,	4 in x 3.48 in. (101.6 mm x 88.4 mm)	
Compression Ratio	9.4:1	
Minimum C.C.A. at 5°C	550	
RPM	1800 rpm	1500 rpm
BHP Minimum REQ"D at Rated kW	48	29
BMEP	81 psi	58 psi

Generator Set Deration Factors

Temperature:
1% for every 10° F above 120° F
1% for every 6°C above 49°C

Altitude
2% for every 1000 feet above
Sea Level
2% for every 305 meters above
Sea Level

Cooling System

High Ambient 105°F(41°C) System Coolant Capacity with Radiator	4.25 US Gal. (16.1L)	
Maximum restriction on discharge side of radiator	5 in wc (125pa)	
Coolant Flow	1800 rpm 22.9 GPM (86.7 LPM)	1500 rpm 19.5 GPM (73.8 LPM)
Heat rejection to coolant at Rated		
Full Load	1600Btu/min (169 MJ/min)	1400Btu/min (148 MJ/min)
Propane		
Heat rejection to coolant at Rated		
Full Load	1600Btu/min (169 MJ/min)	1400Btu/min (148 MJ/min)
Nat. Gas		
Heat rejection to room at Rated		
Full Load	5400Btu/min (570 MJ/min)	4800Btu/min (506 MJ/min)
Propane		
Heat rejection to room at Rated		
Full Load	5400Btu/min (570 MJ/min)	4800Btu/min (506 MJ/min)
Nat. Gas		

Air System

Maximum	1800 rpm	1500 rpm
Air Intake Restriction	12 In wc (2.99 kPa)	12 In wc (2.99 kPa)
Radiator Cooling Air Flow	3225 cfm (98.3 m ³ /min)	2850 cfm (86.7 m ³ /min)
Combustion Air Flow	88.5 cfm (2.7 m ³ /min)	72.8 cfm (2.2 m ³ /min)
Generator Cooling Air Flow	453 cfm (12.8 m ³ /min)	378 cfm (10.7 m ³ /min)

Exhaust System

Exhaust Outlet Connection	2.5 in. NPT	
Maximum Allowable Back Pressure	1.5 In Hg (5.08 kPa)	
Exhaust Gas at Standby Rating	420 cfm (11.9 m ³ /min)	354 cfm (10 m ³ /min)
Exhaust Temp at Standby Rating	1100°F (593°C)	1000°F (538°C)

Fuel System

Consumption at Standby Rating:		
Load	1800 RPM	
	Propane	Natural Gas
	kW	lbs./hr.(kg./hr.)
		CFH(m ³ /hr.)
1/4	7	13.7(6.2)
1/2	15	17.8(8.1)
3/4	22	22.3(10.1)
Full	30	27.0(12.2)
Load	1500 RPM	
	Propane	Natural Gas
	kW	lbs./hr.(kg./hr.)
		CFH(m ³ /hr.)
1/4	6	10.9(4.9)
1/2	13	14.2(6.4)
3/4	20	17.9(8.1)
Full	27	21.5(9.8)
Governor Type	Electronic	
Governor Regulation:	1/4 % Steady State	

Generator

Manufacturer	MagneTek	
Model	MTG22	
Motor Starting KVA, 240/480 Volt WYE at 35% Voltage Dip,100% Voltage Recovery	70 SKVA	
Maximum Motor Starting KVA, Oversized Generator MTG27	35% Voltage Dip 149 SKVA	

Reactances

	480 V	400 V
at 105°C rise	60Hz	50Hz
Synchronous Xd	3.33	2.85
Direct Axis		
Transient X'd	.247	.212
Direct Axis		
Subtransient X'd	.188	.161
Negative Sequence X ₂	.231	.198
Zero Sequence X ₀	.0033	.0029

Lubrication System

Engine Oil Capacity with Filters	4.5 qts. (4.3)	
Oil Filter Type	Spin On	

