



Model 60 RNIL 60 kW Natural Gas\ LP Generator Set

Generator Set Rating

Three Phase	60 Hz	50 Hz
	kW/KVA	kW/KVA
Continuous		
Standby 150°C	60/75	49/56
Prime Power 105°C	51/64	42/53
Single Phase	60 Hz	50 Hz
	kW/KVA	kW/KVA
Continuous		
Standby 150°C	41/41	41/41
Prime Power 105°C	34/34	36/36

Quality Power Producing Equipment

is our business at Elliott MagneTek Power Systems, Inc.. Our power systems offer solutions to requirements for reliable, quality electrical power.

- 100% full load tested.
- Performance supported by prototype testing.
- 12 lead re-connectable AC synchronous generators.
- Solid state automatic voltage regulator.
- 50 or 60 Hz operational.
- Standard Digital Control Panel meeting standards set by NFPA-110.

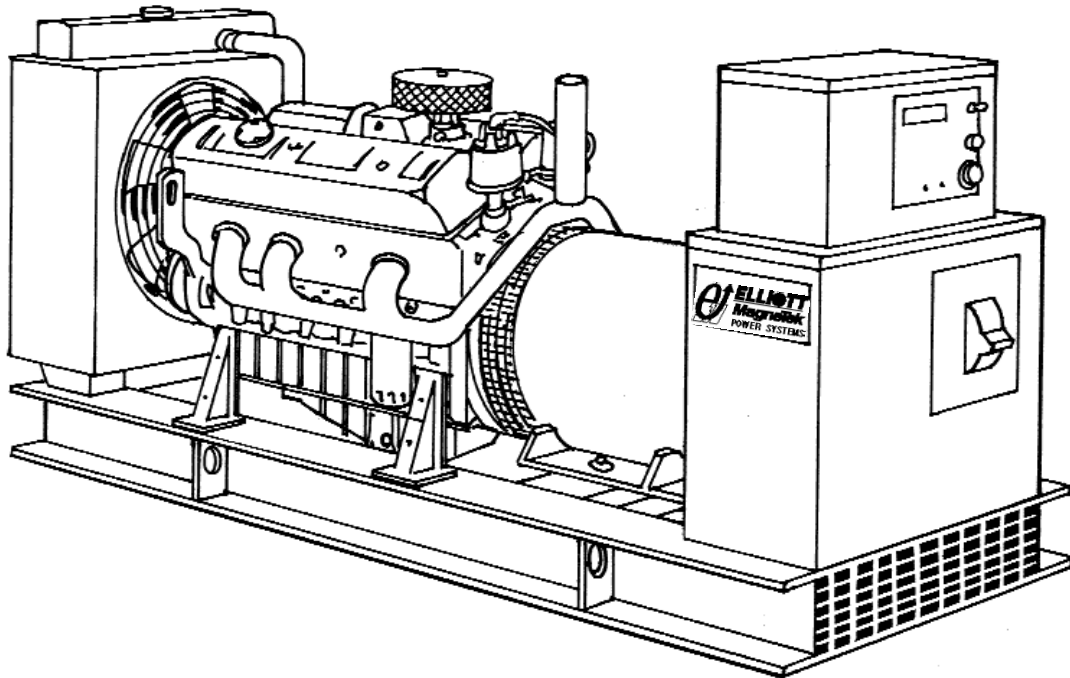

Product Features

System Reliability and Longevity

begin with design experience and integrity. EMPS was formed by two companies with over one hundred years experience producing state-of-the-art power generation equipment. This experience is designed into our generator sets.

Single Source Responsibility:

Product service, support and parts available through EMPS network of distributors.

Accessories and Flexibility

are designed into EMPS' generator sets at the factory level to meet specific application needs.

Organizational Commitment

to innovative, leading edge technology and environmentally friendly electrical products and services.

Generator Set Design Features

Model 60 RN\ L 60 kW NG\ LP Generator Set

Standard Equipment

- * 4 Cycle engine.
- * AC synchronous 12 lead re-connectable brushless alternator.
- * Steel base with vibration isolators between engine, generator and base.
- * Generator mounted terminal and meter /control box.
- * Circuit breaker-mounting provisions.
- * Connection area for main AC terminals and all control wiring
- * 12 volt DC engine electrical system.
- * 12 volt starter motor.
- * Battery charging alternator.
- * Battery rack and cables.
- * Flexible fuel lines.
- * Most metallic parts incorporate our powder paint primer base coat with UV inhibitive enamel top coat.
- * Single stage dry type air cleaner.
- * Corrosion resistant hardware.
- * Oil drain extension plumbed to base rail for convenient connection.
- * Microprocessor based auto start meter/ control panel.
- * Digital read out control system rated to operate from -30° C to 75° C with the following standard displays, shown continuously:
 - ** Generator AC voltage.
 - ** AC amperage:
 - Phase 1-2
 - Phase 2-3
 - Phase 3-1
 - ** Frequency
 - ** Oil Pressure
 - ** Engine Temperature
 - ** Battery Voltage
 - ** Fuel Level (Diesel Only)
- * The following can be displayed using the scroll lock function:
 - ** Run time
 - ** Safety set point for over speed
 - ** Over crank
 - ** High water temperature
 - ** Low oil pressure
- * Voltage adjust rheostat
- * Auto/off /run switch

Generator Specifications

Manufacturer: MagneTek

Insulation: The main stator, main rotor, exciter stator and exciter rotor are all insulated with Class H materials and rated Class F per NEMA MG1 -1.65 and 852757 definition. All materials are non-hygroscopic to prevent fungus growth. A polyester and epoxy combination offers maximum environmental protection.

Main Stator: 2/3 pitch and one slot skewing minimize voltage harmonics and meets telephone influence factor (TIF) per NEMA MG1-22.43. Twelve lead re-connectable design. Coated with anti-abrasive sealer.

Main Rotor: Four pole single piece lamination with full amortisseur windings and coil supports. Winding is precision wet layer wound with epoxy resin and dynamically balanced to two mil in two planes. Production over speed tested at 125% for 15 minutes. All materials are non-hygroscopic to prevent fungus growth.

Exciter: Brushless, three phase, six-pole rotor, and production over speed tested at 125% operating speed.

Rotating Diode: Sealed full wave with metal oxide surge suppressor

Bearing: Double-sealed, permanently lubricated, 50,000 hour B-10 life including magnetic pull.

Drive Coupling: Positive alignment, flexible drive discs.

Automatic Voltage Regulator Specifications

Operation: Volts per hertz, three phase sensing with overload and loss of sensing protection.

Construction: Solid state, modular: fully sealed and potted design provides component protection from corrosive environments and vibration.

Voltage Regulation: +/- 1% voltage regulation no load to full rated load: +/- 1/2% voltage regulation at steady state conditions.

Radio Interference (RFI): Integral filter provides suppression of conducted electromagnetic interference to levels meeting most commercial requirements.

Voltage Selections and Full Load Amperages at Standby Rating

Three Phase

60 Hz Amperage	50 Hz Amperage
120/208	208 110/190 186
120/240	180 120/208 170
277/480	90 230/400 88
347/600	72 240/415 85

*Single Phase

60 Hz Amperage	50 Hz Amperage
120/240	170 110/220 186

All voltages listed are available and/or re-connectable with the exception of the three phase, 60 Hz, 347/600 volt generator which is application specific. For other voltages, contact your EMPS distributor. All output amperage ratings listed above are at standby rating.

*Single Phase amperage based on standard generator and unity power factor. For full single phase output use generator model MTG35.

Application and Performance Data

MagneTek Alternator Model MTG27 is standard with this package.

Larger generators may be required to meet certain application specific requirements such as Single Phase, Motor Starting and Non Linear Loads. The Maximum Generator rating available in this package is MTG35.

Technical Specifications

Model 60 RN/L 60 kW Diesel Generator Set

Engine Specifications

Manufacturer	General Motors	
Model	5.7 L	
Aspiration	Natural	
Cylinders	V-8	
Displacement	350 In ³ . (5.7 L)	
Bore and Stroke,	4 in x 3.48 in. (101.6 mm x 88.4 mm)	
Compression Ratio	9.4:1	
Minimum C.C.A. at 5°C	550	
RPM	1800 rpm	1500 rpm
BHP Minimum REQ"D at Rated kW	97	93
BMEP	122 psi	140 psi

Generator Set Deration Factors

Temperature:
1% for every 10° F above 120° F
1% for every 6°C above 49°C

Altitude
2% for every 1000 feet above
Sea Level
2% for every 305 meters above
Sea Level

Cooling System

High Ambient 117°F (47°C) System
Coolant Capacity with Radiator
4.5 US Gal. (17 L)

Maximum restriction on discharge side of
radiator 5 In wc (125 Pa)

	1800 rpm	1500 rpm
Coolant Flow	27 GPM (102 LPM)	22 GPM (83 LPM)

Heat Rejection
to Coolant at Rated
Full Load 3350 Btu/min 2250 Btu/min
Nat. Gas (353 MJ/min) (237 MJ/min)

Heat Rejection
to Coolant at Rated
Full Load 3350 Btu/min 2250 Btu/min
Propane (353 MJ/min) (237 MJ/min)

Heat Rejection
to Room at Rated
Full Load 10050 Btu/min 6750 Btu/min
Nat. Gas (1060 MJ/min) (712 MJ/min)

Heat Rejection
to Room at Rated
Full Load 10050 Btu/min 6750 Btu/min
Propane (1060 MJ/min) (712 MJ/min)

Air System

	1800 rpm	1500 rpm
Maximum Air Intake Restriction	12 In wc (2.99 kPa)	12 In wc (2.99 kPa)
Radiator Cooling Air Flow	4300 cfm (121.7 m ³ /min)	3800 cfm (107.5 m ³ /min)
Combustion Air Flow	160 cfm (4.5 m ³ /min)	135 cfm (3.8 m ³ /min)
Generator Cooling Air Flow	1003 cfm (28.4 m ³ /min)	860 cfm (24.3 m ³ /min)

Exhaust System

Exhaust Outlet Connection	3.0 in. NPT
Maximum Allowable Back Pressure	1.5 In Hg (5.08 kPa)
Exhaust Gas Flow at Standby Rating	640 cfm (18.1 m ³ /min) 550 cfm (15.6 m ³ /min)
Exhaust Temp at Standby Rating	1250°F (677°C) 1125°F (607°C)

Fuel System

	Consumption at Standby Rating:	
	Propane	Natural Gas
kW	lbs./hr.(kg./hr.)	CFH(m ³ /hr.)
1/4	15	398(11.3)
1/2	30	515(14.6)
3/4	45	647(18.3)
Full	60	780(22.1)

Load	1500 RPM	
	Propane	Natural Gas
kW	lbs./hr.(kg./hr.)	CFH(m ³ /hr.)
1/4	12	332(9.4)
1/2	24	430(12.2)
3/4	36	540(15.3)
Full	49	651(18.4)

Governor Type Electronic
Governor Regulation: 1/4% Steady State

Generator

Manufacturer MagneTek
Model MTG27
Motor Starting KVA, 240/480 Volt WYE at 35% Voltage Dip,100% Voltage Recovery 149 SKVA

Maximum Motor Starting KVA,35% Voltage Dip Oversized Generator MTG35 288 SKVA

Reactances

	480 V	400 V
at 105°C rise	60Hz	50Hz
Synchronous Xd	3.3	3.42
Direct Axis		
Transient X'd	.243	.229
Direct Axis		
Subtransient X'd	.174	.164
Negative Sequence X ₂	.228	.214
Zero Sequence X ₀	.0037	.0034

Lubrication System

Engine Oil Capacity with Filters 5qts.. (5.7 L)
Spin On
Oil Filter Type

Model 60 RN\ L 60 kW NG\ LP Generator Set

Options:

Generator

- * Upsized
- * Tropical winding protection
- * Space heater
- * Series boost
- * UL listed mainline circuit breaker

Control

- * Remote alarm annunciator
- * Emergency stop
- * Multi-point dry contact board.
- * NFPA 110 Compliance
- * Low Temperature Display Heater

Engine

- * Battery/Battery heater
- * Battery charger
- * Engine pre-heater
- * Fuel/ water separator

Generator Set

- * EMPS automatic transfer switch
- * Industrial silencer
- * Residential silencer
- * Critical silencer
- * Weather protective enclosure
- * Sound attenuation

DOOR SWING: ENGINE DOOR: 28.75 SECURITY DOOR: 32.56
 MACHINE WEIGHT: OPEN DRY WEIGHT 1931 LBS [875.9 KG] ENCLOSED DRY WEIGHT 2406 LBS [1091.3 KG]

NOTES:
 PRELIMINARY DRAWING DIMENSIONS SUBJECT TO CHANGE WITHOUT NOTICE.

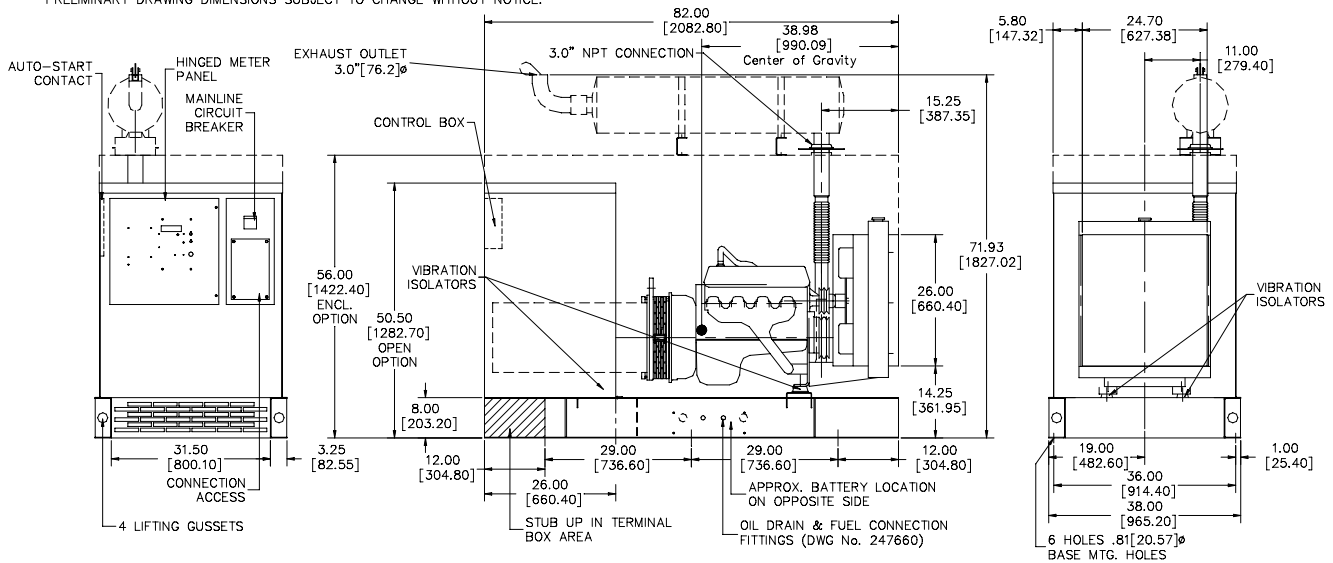

58 Elliott Power Drive
 P.O. Box 403
 Lexington, TN 38351
 Tel: 901-967-9393
 Fax: 901-968-0161

Distributed by:



All specifications subject to change without notice. Printed in the USA

Updated 2/00